

2021/2022
Product
Catalogue

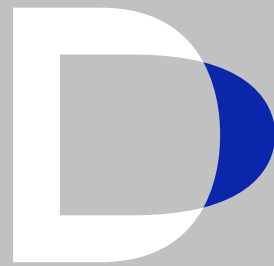

Delta Line

Moving together

Stepper



Permanent Magnet Stepper

p.265



Flat Hybrid Stepper

p.353



Hybrid Stepper S series

p.277



Hybrid Stepper SH series

p.287



Hybrid Stepper STC series

p.327

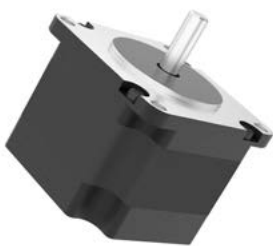

3-Phase Hybrid Stepper

p.337



Hollow Shaft Stepper

p.345 - NEW



Hybrid Stepper with Encoder

p.357



IP65 Hybrid Stepper

p.373

Stepper Motors

Technical introduction		262
Permanent Magnet Stepper motors	Torque* (Nm)	265
15PM12	0,003...0,004	266
20PM18	0,005	267
25PM15	0,01...0,016	268
35PM16...22	0,04...0,055	269
42PM17...22	0,05...0,06	271
57PM25	0,12...0,15	273
Hybrid Stepper motors - S series	Torque* (Nm)	277
57S41...76	0,288...1,25	278
86S67...125	2,3...7,6	282
Hybrid Stepper motors - SH series High Torque	Torque* (Nm)	287
20SH33...42	0,018...0,03	288
25SH23	0,033	290
28SH32...51	0,043...0,12	291
35SH26...36	0,07...0,14	294
39SH20...38	0,065...0,29	297
42SH33...60	0,158...0,8	300
42SH33...47M - step 0,9°	0,158...0,44	304
57SH41...76	0,39...1,89	307
57SH41...76M - step 0,9°	0,39...1,8	311
60SH45...86	0,78...3,1	314
86SH65...156	2,6...12,1	318
110SH99...201	11,2...28	323
Hybrid Stepper motors - STC series Hyper Torque	Torque* (Nm)	327
20STC33...40	0,022...0,036	328
28STC32...51	0,08...0,18	330
57STC41...76	0,6...2,3	333
3-Phase Hybrid Stepper motors	Torque* (Nm)	337
42 3P24...39	0,08...0,2	338
57 3P42...79	0,45...1,5	340
60 3P53	0,9	343
Hollow Shaft Stepper motors - NEW	Torque* (Nm)	345
20STC40 H	0,036	346
28STC51 H	0,12	347
35STC38 H	0,23	348
42STC47 H	0,44	349
57STC76 H	2,3	350
86SH118 H	6	351
Flat Hybrid Stepper motors	Torque* (Nm)	353
28S10	0,01	354
63S10	0,064	355
Stepper motors with Encoder	Torque* (Nm)	357
SM42 054...080 -E	0,22...0,75	358
SM60 066...107 -E	1...3	362
SM86 084...172 -E	3,5...12	366
IP65 Hybrid Stepper motors	Torque* (Nm)	373
SM28 051...070 - IP65	0,071...0,127	374
SM42 097...127 - IP65	0,16...0,72	376
SM42 097...127 -E - IP65 with Encoder	0,16...0,72	379
SM57 070...093 - IP65	1,2...2,2	382
SM57 101...136 -E - IP65 with Encoder	0,7...1,95	384

* Holding Torque

Term	
Rated voltage	Voltage necessary to reach the nominal current per phase.
Current/Phase	The current supplied to the motor phases that will not exceed, at an ambient temperature of 20°C, the thermal limits of the motor.
Resistance/Phase	Winding resistance per phase. Tolerance +/- 12%, steady state.
Inductance/Phase	Winding inductance per phase measured at 1kHz.
Holding Torque	The torque generated by the motor at nominal current.
Rotor Inertia	Is the mass moment of inertia of the rotor, based on the axis of rotation.
Detent Torque	The torque required to rotate a non-energized step motor.
Number of leads	Number of lead wires available to connect the motor.
Length	Total motor length.
Weight	Total motor mass.
Step angle	Number of angular degrees the motor moves per full-step
Step angle accuracy	The percentage position error per full step, at no load and nominal current. This error is not cumulative between steps.
Insulation class	The electrical insulation system for wires and other wire-wound electrical components is divided into different classes by temperature and temperature rise. The electrical insulation system is sometimes referred to as insulation class or thermal classification.
Ambient temperature	Temperatures at which the motor can operate.
Max. Temp. Rise (rated current 2 phase on)	Maximum temperature rise for the motor at rated voltage and two phases
Max. shaft radial play	The shaft displacement perpendicular to the shaft due to a side force applied perpendicular to the shaft axis.
Max. shaft axial play	Axial shaft displacement occurring during a reversal of an axial force on the shaft.
Max. Radial force	Maximum force that can be applied to the shaft in the radial direction (any direction perpendicular to the motor shaft axis).
Max. Axial force	Maximum force that can be applied to the shaft in the axial direction (in the same axis as or parallel to the motor shaft axis).
Dielectric strength	A dielectric test (also known as hipot or high potential test) is performed on all motors under 500V phases to the housing and during 5 seconds after voltage ramp up. Maximum allowed leakage is 1mA
Insulation resistance	The measurement of insulation resistance is carried out by means of a megohmmeter - high resistance range ohmmeter. DC voltage is applied between the windings and the ground of the motor.

Glossary

Product families

Permanent Magnet Stepper motors
Hybrid Stepper motors
3-Phase Hybrid Stepper motors
Hollow Shaft Stepper motors
Flat Hybrid Stepper motors
Stepper motors with Encoder
IP65 Hybrid Stepper motors

A stepper motor is an electromechanical device which converts electrical pulses into discrete mechanical movements. The shaft or spindle of a stepper motor rotates in discrete step increments when electrical command pulses are applied to it in the proper sequence. The motors rotation has several direct relationships to these applied input pulses. The sequence of the applied pulses is directly related to the direction of motor shafts rotation. A stepper motor can be a good choice whenever controlled movement is required. They can be used to advantage in applications where you need to control rotation angle, speed, position and synchronism.

Main advantages

- 1 The rotation angle of the motor is proportional to the input pulse.
- 2 Precise positioning and repeatability of movement since good stepper motors have an accuracy of 3 - 5% of a step and this error is non cumulative from one step to the next.
- 3 Excellent response to starting/stopping/reversing.
- 4 Very reliable since there are no contact brushes in the motor. Therefore the life of the motor is simply dependent on the life of the bearing.
- 5 A wide range of rotational speeds can be realized as the speed is proportional to the frequency of the input pulses.

Often referred to as "tin can" or "can stack" motor the permanent magnet step motor is a low cost and low resolution type motor. PM motors have permanent magnets added to the motor structure. The rotor no longer has teeth, instead the rotor is magnetized with alternating north and south poles situated in a straight line parallel to the rotor shaft. These motors offer good torque at lower speed.

Permanent Magnets stepper motors

The hybrid stepper motor is more expensive than the PM stepper motor but provides better performance with respect to step resolution, torque and speed. This motor combines the best features of both the PM and Variable Reluctance stepper motors. The rotor is multi-toothed and contains an axially magnetized concentric magnet around its shaft. The teeth on the rotor provide an even better path which helps guide the magnetic flux to preferred locations in the air gap. This further increases the detent, holding and dynamic torque characteristics of the motor when compared with both the VR and PM types.

Hybrid Stepper motors (2-Phase)

3-Phase technology in hybrid stepper motor is used mainly where ultra-low vibration and very low noise levels are required. The drive circuit of these motors is simplified because it is driven with a star wiring connection. The use of three phases inherently helps to reduce torque ripple and smooth motor performance. An example of an ideal application is in performance lighting, where quick movement and quiet operation are required.

3-Phase Hybrid Stepper motors

Our Hybrid stepper motors are also available equipped with an optical incremental encoder to increase the motion precision. Thanks to the encoder, the drive knows the position (or the speed) of the motor in real time and can perform adjustments to align the real condition with the condition requested by the system. The presence of an encoder is highly recommended when is critical to know the status of the motor (both position and speed) in every instant.

Stepper motors with integrated Encoder

Technical introduction

Composition Hybrid Stepper

- 1 Front Endbell
- 2 Stator & Coils
- 3 Shaft
- 4 Washer
- 5 Ball bearings
- 6 Rotor cup
- 7 Magnet
- 8 Rear Endbell

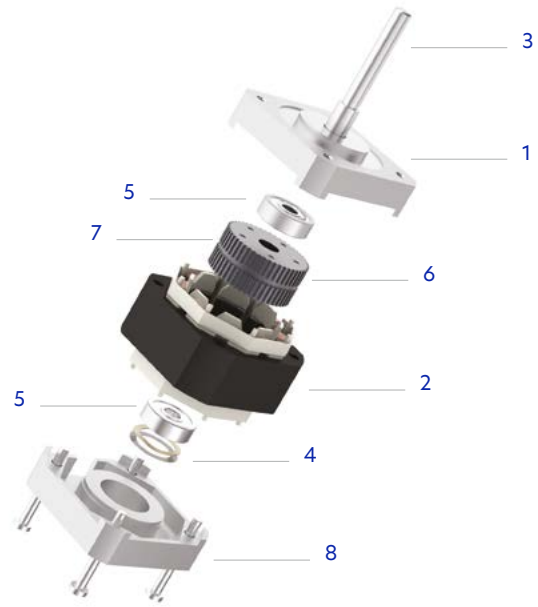

Composition PM Stepper

- 1 Sleeve bearing
- 2 Shaft
- 3 Front flange
- 4 Front cover/stator
- 5 Rotor
- 6 Windings
- 7 Inner stator
- 8 Rear cover/stator

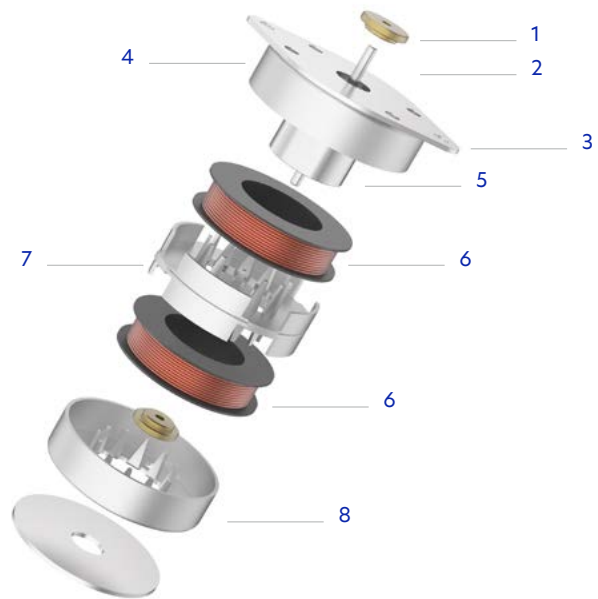

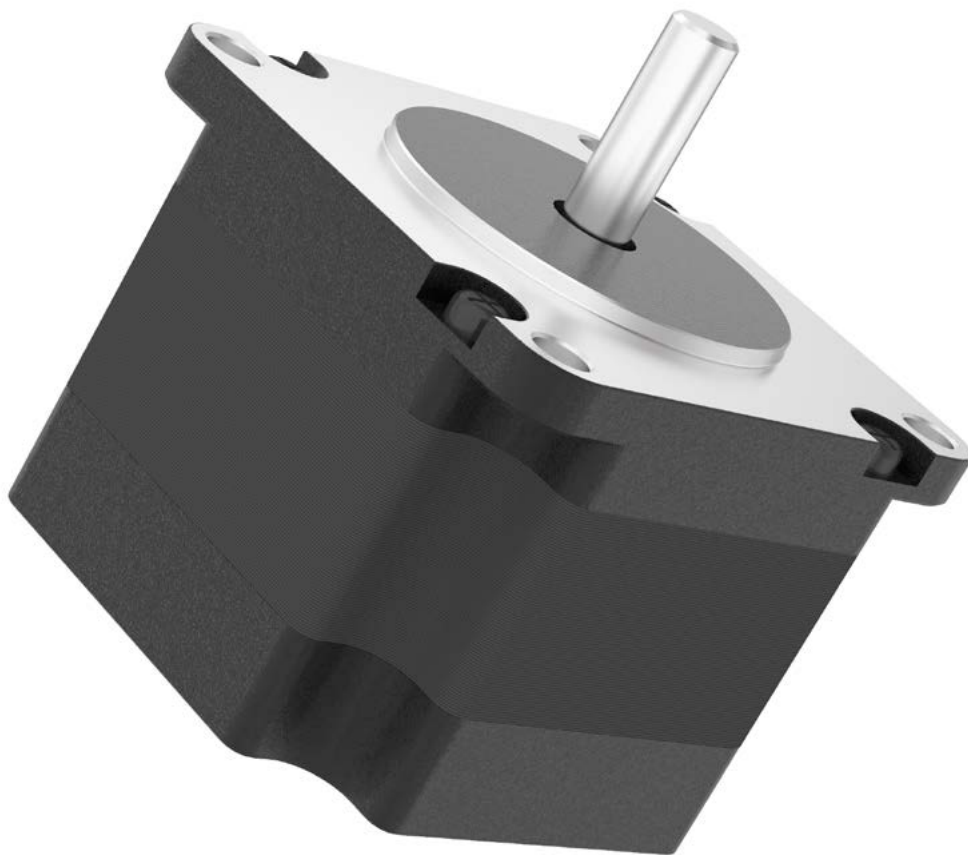

Stepper motors
3-Phase Hybrid

Advantages at a glance

- Low noise and losses
- High torque
- Smooth precise movement

3-Phase technology in hybrid stepper motor is used mainly where ultra-low vibration and very low noise levels are required. The drive circuit of these motors is simplified because it is driven with a star wiring connection. The use of three phases inherently helps to reduce torque ripple and smooth motor performance. An example of an ideal application is in performance lighting, where quick movement and quiet operation are required.

3-Phase Hybrid Stepper motors	Torque* (Nm)	
42 3P24	0,080	338
42 3P39	0,200	339
57 3P42	0,450	340
57 3P56	0,900	341
57 3P79	1,500	342
60 3P53	0,900	343

* Holding Torque

Hybrid Stepper Motor 423P24

3-Phase

□ 42mm

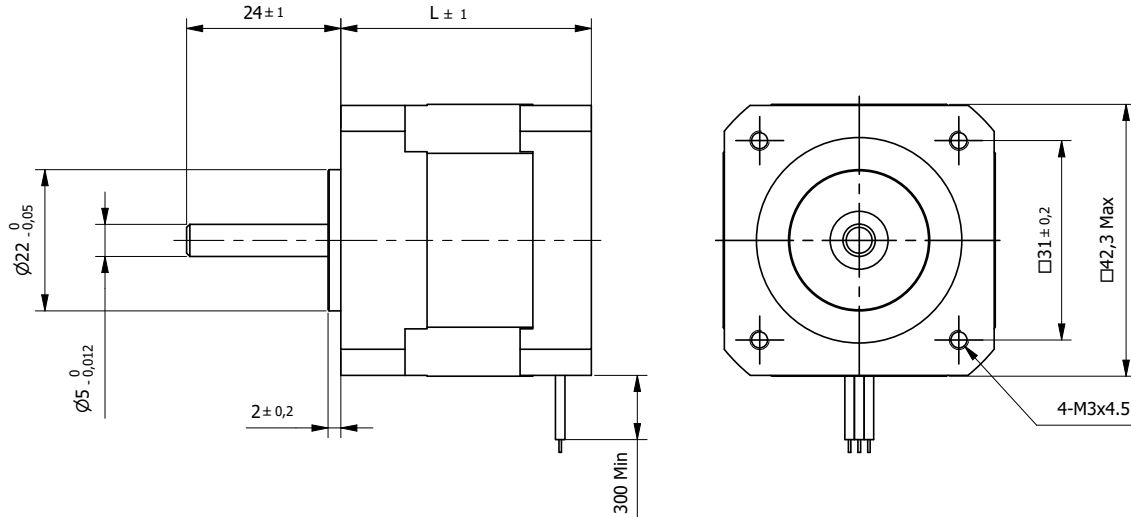

BE Version: Rear shaft 13mm - 2x M2.5 on diameter 19.05mm

Specification			
Model	...0903A		
1	Rated Voltage	V	5,58
2	Current/Phase	A	0,9
3	Resistance/Phase	Ω	6,2
4	Inductance/Phase	mH	3,2
5	Holding Torque	Nm	0,08
6	Rotor Inertia	gcm ²	20
7	n° of Leads		3
8	Length (L)	mm	24
9	Weight	Kg	0,14

Characteristics	
Item	
Step angle	1,2°
Step angle Accuracy	±5%
Insulation Class	B
Protection Class	IP30
Ambient Temperature	-20°C to +50°C
Max. Temp. Rise (rated current, 2-phase on)	80°C
Max. Shaft Radial play (450g load)	0,02mm
Max. Shaft Axial play (450g load)	0,08mm
Max. Radial Force (20mm from front flange)	28N
Max Axial Force	10N
Dielectric Strength (for 1 min.)	500 VAC
Insulation Resistance (min. 500 VDC)	100 Mohm

Standard Combination		
Encoder	Gearbox	Drive
E3	GYP42	Aries
E4	42JMS	Libra
E5		Orion
		Aquarius

* other options on request

Connection			
Lead n°	Color	Gauge	Function
1	Red	UL1061 AWG26	Phase U
2	Yellow		Phase V
3	Blue		Phase W

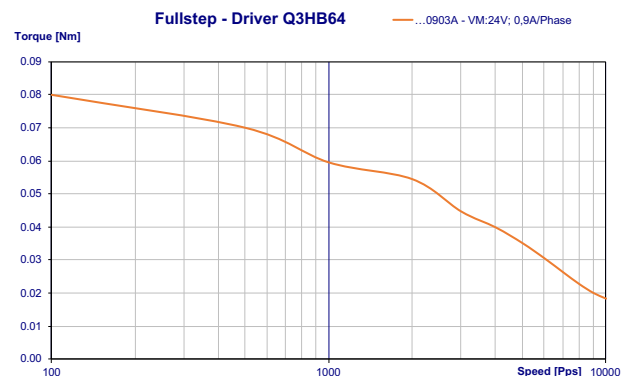

Hybrid Stepper Motor 423P39

3-Phase

□ 42mm

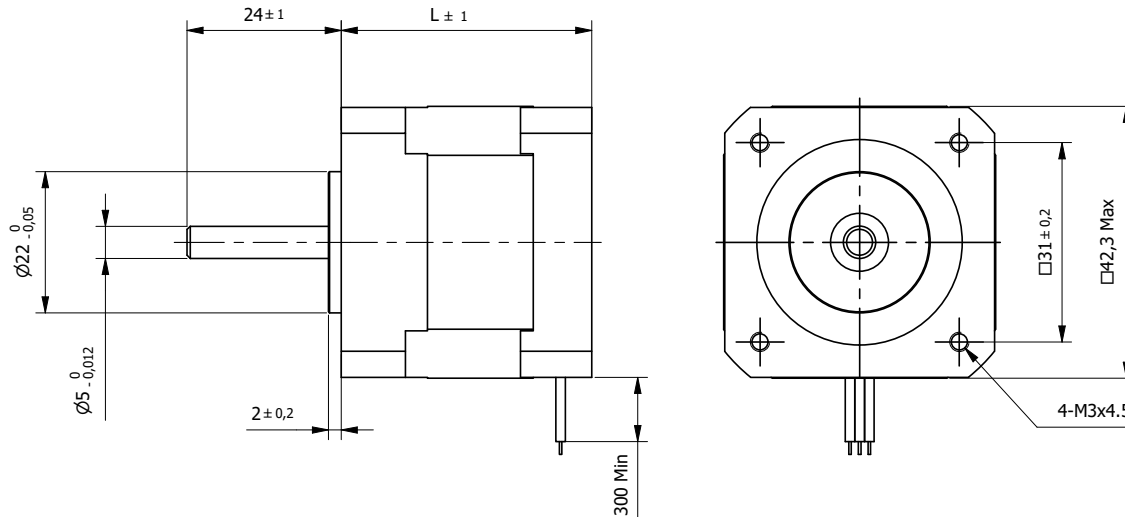

BE Version: Rear shaft 13mm - 2x M2.5 on diameter 19.05mm

Specification			
Model	...2403A		
1	Rated Voltage	V	2,88
2	Current/Phase	A	2,4
3	Resistance/Phase	Ω	1,2
4	Inductance/Phase	mH	0,8
5	Holding Torque	Nm	0,2
6	Rotor Inertia	gcm ²	54
7	n° of Leads		3
8	Length (L)	mm	39
9	Weight	Kg	0,28

Characteristics	
Item	
Step angle	1,2°
Step angle Accuracy	±5%
Insulation Class	B
Protection Class	IP30
Ambient Temperature	-20°C to +50°C
Max. Temp. Rise (rated current, 2-phase on)	80°C
Max. Shaft Radial play (450g load)	0,02mm
Max. Shaft Axial play (450g load)	0,08mm
Max. Radial Force (20mm from front flange)	28N
Max Axial Force	10N
Dielectric Strength (for 1 min.)	500 VAC
Insulation Resistance (min. 500 VDC)	100 Mohm

Connection			
Lead n°	Color	Gauge	Function
1	Red	UL1061 AWG26	Phase U
2	Yellow		Phase V
3	Blue		Phase W

Standard Combination		
Encoder	Gearbox	Drive
E3	GYP42	Aries
E4	42JMS	Libra
E5		Orion
		Aquarius

* other options on request

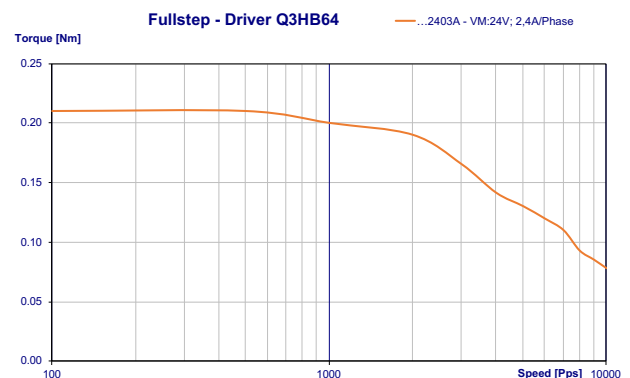

Hybrid Stepper Motor 573P42

3-Phase

□ 57mm

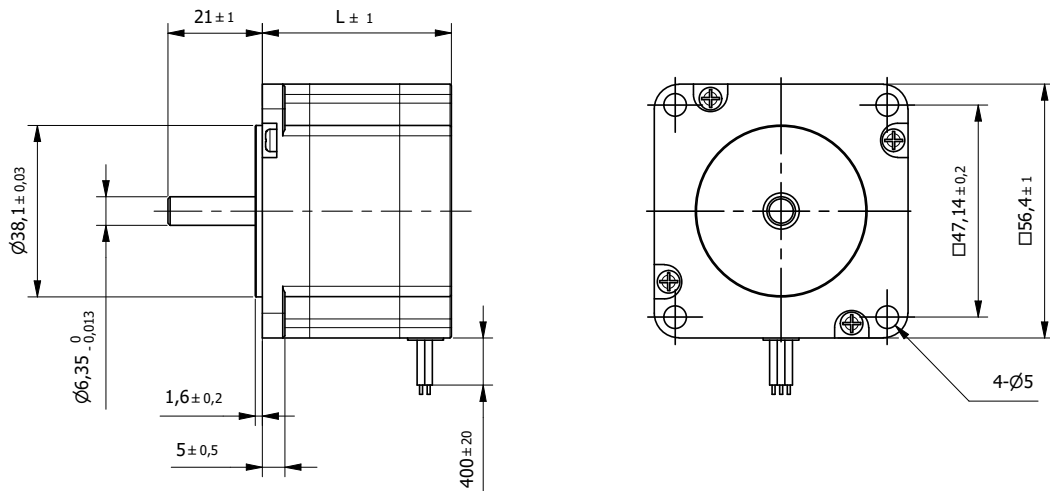

BE Version: Rear shaft 13mm - 2x M2.5 on diameter 46mm

Specification			
Model	573P42		
1	Rated Voltage	V	6,76
2	Current/Phase	A	5,2
3	Resistance/Phase	Ω	1,3
4	Inductance/Phase	mH	1,4
5	Holding Torque	Nm	0,45
6	Rotor Inertia	gcm ²	110
7	n° of Leads		6
8	Length (L)	mm	42
9	Weight	Kg	0,45

Characteristics	
Item	
Step angle	1,2°
Step angle Accuracy	±5%
Insulation Class	B
Protection Class	IP30
Ambient Temperature	-20°C to +50°C
Max. Temp. Rise (rated current, 2-phase on)	80°C
Max. Shaft Radial play (450g load)	0,02mm
Max. Shaft Axial play (450g load)	0,08mm
Max. Radial Force (20mm from front flange)	75N
Max Axial Force	15N
Dielectric Strength (for 1 min.)	500 VAC
Insulation Resistance (min. 500 VDC)	100 Mohm

Connection			
Lead n°	Color	Gauge	Function
1	Red	UL1430 AWG26	Phase U
2	Orange		Phase U
3	White		Phase V
4	Blue		Phase V
5	Yellow		Phase W
6	Green		Phase W

Standard Combination		
Encoder	Gearbox	Drive
E3	GYP56	Libra
E4	56JMS	Sagittarius
E5		Aquarius
		Andromeda

* other options on request

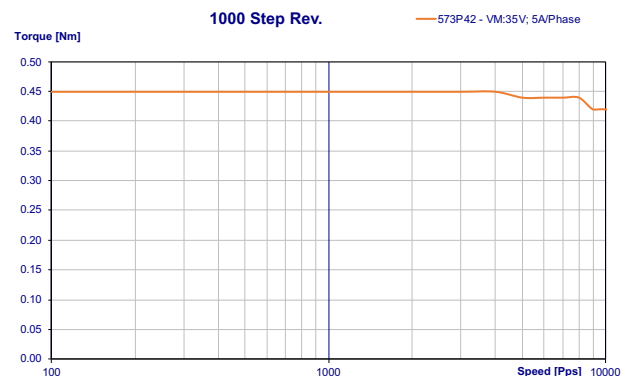

Hybrid Stepper Motor 573P56

3-Phase

□ 57mm

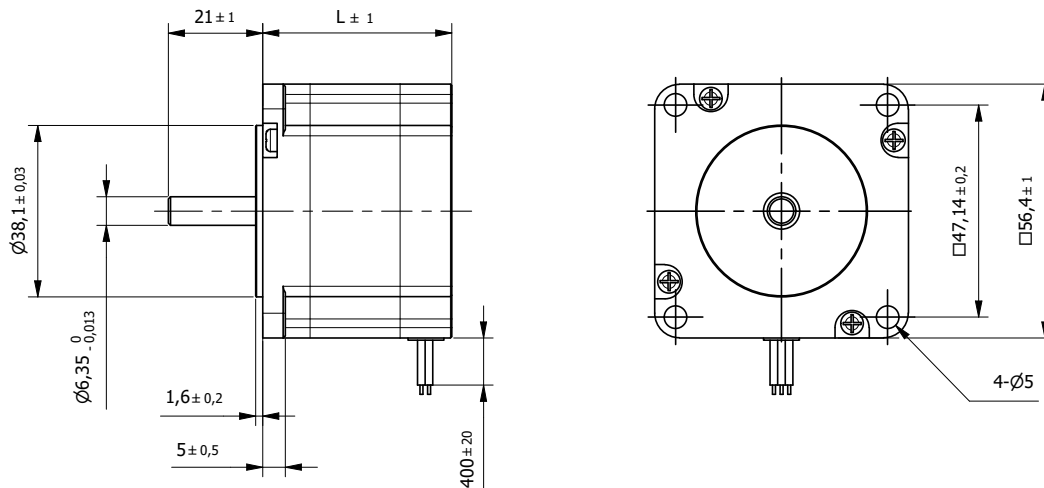

BE Version: Rear shaft 13mm - 2x M2.5 on diameter 46mm

Specification			
Model	573P56		
1	Rated Voltage	V	4
2	Current/Phase	A	5,6
3	Resistance/Phase	Ω	0,7
4	Inductance/Phase	mH	1,7
5	Holding Torque	Nm	0,9
6	Rotor Inertia	gcm ²	300
7	n° of Leads		6
8	Length (L)	mm	56
9	Weight	Kg	0,75

Characteristics	
Item	
Step angle	1,2°
Step angle Accuracy	±5%
Insulation Class	B
Protection Class	IP30
Ambient Temperature	-20°C to +50°C
Max. Temp. Rise (rated current, 2-phase on)	80°C
Max. Shaft Radial play (450g load)	0,02mm
Max. Shaft Axial play (450g load)	0,08mm
Max. Radial Force (20mm from front flange)	75N
Max Axial Force	15N
Dielectric Strength (for 1 min.)	500 VAC
Insulation Resistance (min. 500 VDC)	100 Mohm

Connection			
Lead n°	Color	Gauge	Function
1	Red	UL1430 AWG26	Phase U
2	Orange		Phase U
3	White		Phase V
4	Blue		Phase V
5	Yellow		Phase W
6	Green		Phase W

Standard Combination		
Encoder	Gearbox	Drive
E3	GYP56	Libra
E4	56JMS	Sagittarius
E5		Aquarius
		Andromeda

* other options on request

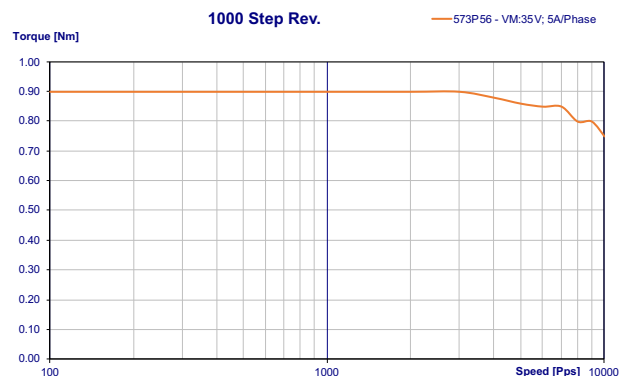

Hybrid Stepper Motor 573P79

3-Phase

□ 57mm

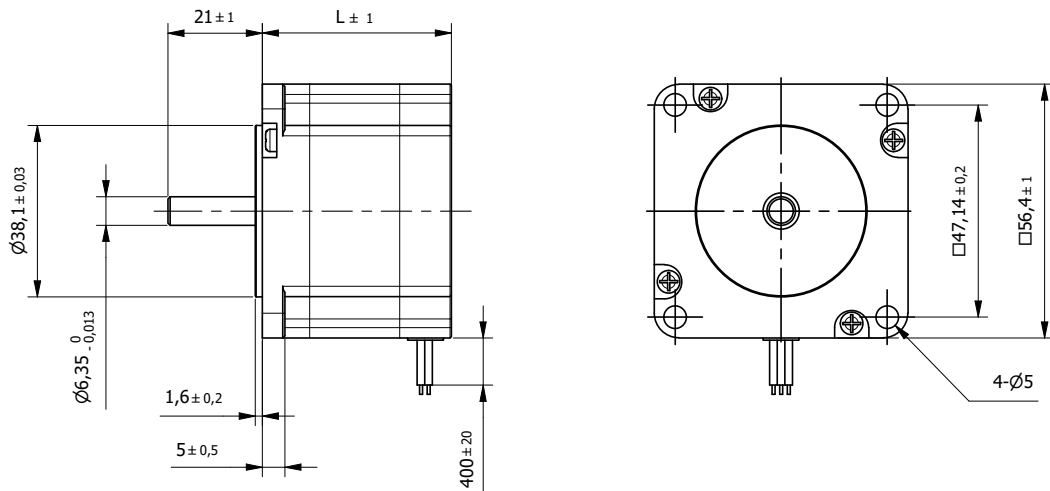

BE Version: Rear shaft 13mm - 2x M2.5 on diameter 46mm

Specification			
Model	573P79		
1	Rated Voltage	V	6
2	Current/Phase	A	5,8
3	Resistance/Phase	Ω	1,05
4	Inductance/Phase	mH	2,4
5	Holding Torque	Nm	1,5
6	Rotor Inertia	gcm ²	480
7	n° of Leads		6
8	Length (L)	mm	79
9	Weight	Kg	1,1

Characteristics	
Item	
Step angle	1,2°
Step angle Accuracy	±5%
Insulation Class	B
Protection Class	IP30
Ambient Temperature	-20°C to +50°C
Max. Temp. Rise (rated current, 2-phase on)	80°C
Max. Shaft Radial play (450g load)	0,02mm
Max. Shaft Axial play (450g load)	0,08mm
Max. Radial Force (20mm from front flange)	75N
Max Axial Force	15N
Dielectric Strength (for 1 min.)	500 VAC
Insulation Resistance (min. 500 VDC)	100 Mohm

Connection			
Lead n°	Color	Gauge	Function
1	Red	UL1430 AWG26	Phase U
2	Orange		Phase U
3	White		Phase V
4	Blue		Phase V
5	Yellow		Phase W
6	Green		Phase W

Standard Combination		
Encoder	Gearbox	Drive
E3	GYP56	Libra
E4	56JMS	Sagittarius
E5		Aquarius
		Andromeda

* other options on request

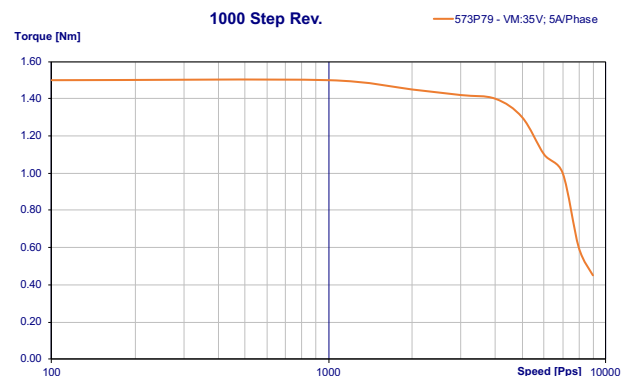

Hybrid Stepper Motor 603P53

3-Phase

□ 60mm

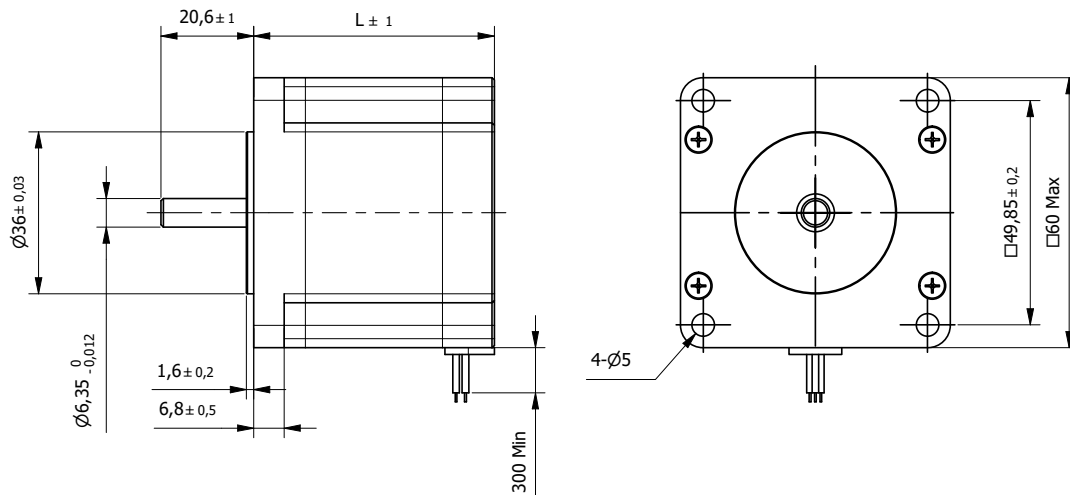

BE Version: Rear shaft 13mm - 2x M2.5 on diameter 46mm

Specification			
Model	...1503		
1	Rated Voltage	V	6,75
2	Current/Phase	A	1,5
3	Resistance/Phase	Ω	4,5
4	Inductance/Phase	mH	12
5	Holding Torque	Nm	0,9
6	Rotor Inertia	gcm ²	260
7	n° of Leads		3
8	Length (L)	mm	53,5
9	Weight	Kg	0,8

Characteristics	
Item	
Step angle	1,2°
Step angle Accuracy	±5%
Insulation Class	B
Protection Class	IP30
Ambient Temperature	-20°C to +50°C
Max. Temp. Rise (rated current, 2-phase on)	80°C
Max. Shaft Radial play (450g load)	0,02mm
Max. Shaft Axial play (450g load)	0,08mm
Max. Radial Force (20mm from front flange)	75N
Max Axial Force	15N
Dielectric Strength (for 1 min.)	500 VAC
Insulation Resistance (min. 500 VDC)	100 Mohm

Connection			
Lead n°	Color	Gauge	Function
1	Red	UL1061 AWG26	Phase U
2	Green		Phase V
3	White		Phase W

Standard Combination		
Encoder	Gearbox	Drive
E3	GYP56	Libra
E4	56JMS	Sagittarius
E5		Aquarius
		Andromeda

* other options on request

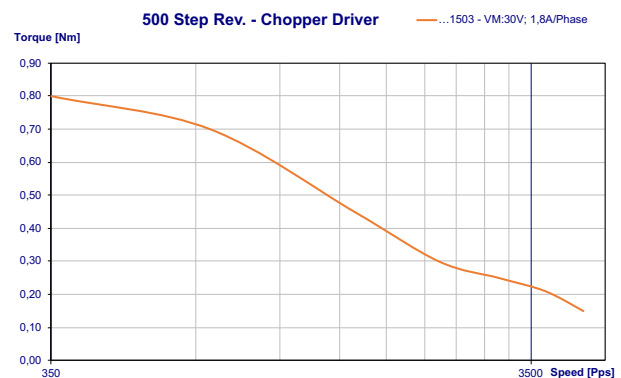

Delta Line SA

Via Prè d'Ià 1
CH - 6814 Lamone
Switzerland

ph. +41 (0)91 612 85 00
fax. +41 (0)91 612 85 19

www.delta-line.com
info@delta-line.com

Delta Line North America, Inc

DTC Tech
4600 South Syracuse, 9th Floor
Denver, CO 80237, USA

ph. +1 303 256 6212

www.delta-line.com
infous@delta-line.com

