

to examine data:

- dimensions
- electrical data
- ...
- ...

consider and release

customer .....

date/signature .....

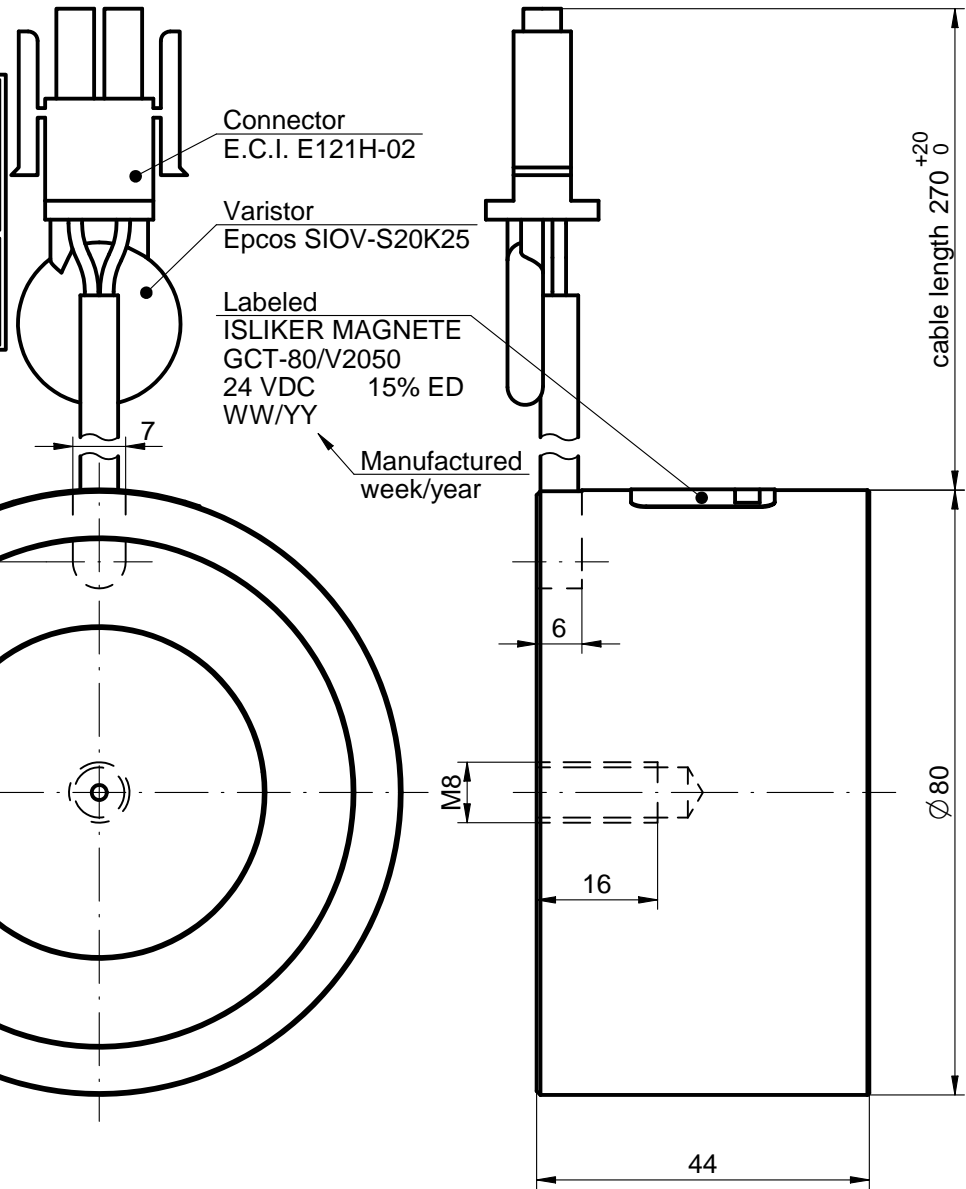

(1:2)

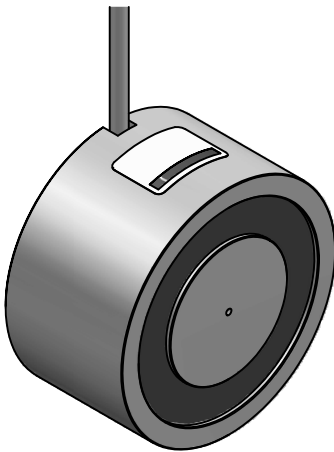

Type	GCT-80-15W-24/V2050		
IM item No.	155.00165		
Customer ident			
Un	Starting: 24	Holding: 14.82	VDC
P20	36.7	14	W
R20	15.69	15.69	Ohm ±5%
In	1.529	0.944	A
Duty cycle	15	100	%
Fn (0.0mm)		2700	N
Fn (0.3mm)	>1500		N
Max. ambient temp.	35		°C
Inductance	81.8		mH (1kHz)
Surface treatment	Zinc plating 5~8µm (blue passivated)		

IM item No.: 155.00165

IM item No.:

Material:

Weight: 1.460 kg

Subst. for:

Date:

A4

**GCT-80/V2050**  
Data sheet (36.7 Watt)

Scale:

1:1

Drawn: 31.01.17 Sf

Checked: 31.01.17 Ep



**ISLIKER MAGNETE**

CH - 8450 Andelfingen  
www.islikermagnete.ch

Page:

1 / 1

**109-167**

Index:

-

This document remains the property of ISLIKER MAGNETE and may not be copied or handed over to third parties without the express consent of ISLIKER MAGNETE.