

to examine data:

- dimensions
- electrical data
- ...
- ...

consider and release

customer

date/signature

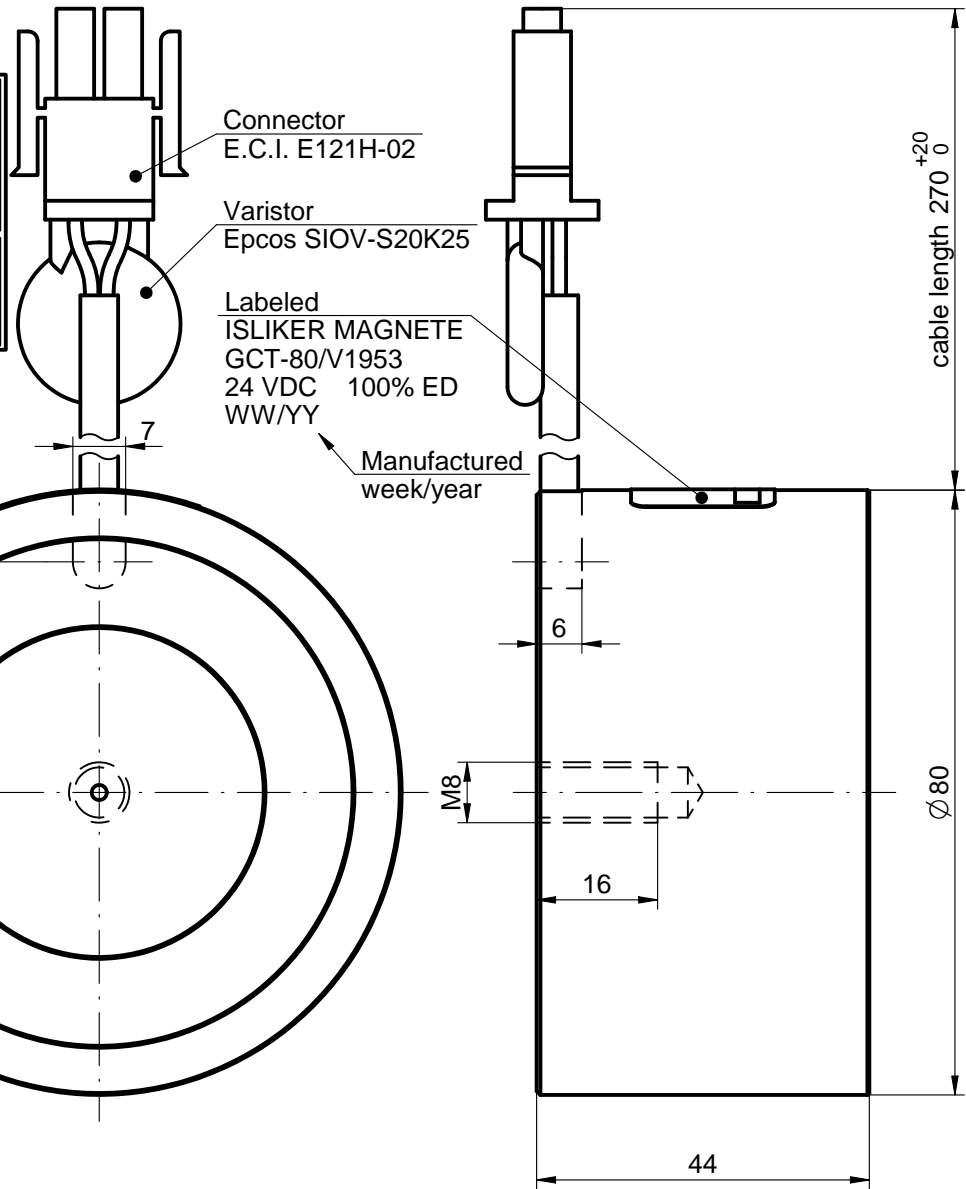

(1:2)



Type : GCT-80-100W-24/V1953
 IM item No. : 155.00064
 Customer ident :

Un : 24 VDC
 P20 : 14 W
 R20 : 41.1 Ohm ±5%
 In : 0.583 A
 Duty cicle : 100 %
 Fn (0mm) : 2700 N
 Fn (0.3mm) : >1000 N

Max. ambient temp.: 35 °C
 Inductance : 190 mH (1kHz)
 Surface treatment : Zinc plating 5~8µm (blue passivated)

IM item No.: 155.00064

IM item No.:

Material:

Weight: 1.460 kg

Subst. for:

Date:

A4

GCT-80/V1953

Data sheet

Scale:

1:1

Drawn: 27.03.14 Sf

Checked: 05.03.15 Ep

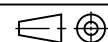

ISLIKER MAGNETE

CH - 8450 Andelfingen
 www.islikermagnete.ch

Page:

1 / 1

108-175

Index:

b

This document remains the property of ISLIKER MAGNETE and may not be copied or handed over to third parties without the express consent of ISLIKER MAGNETE.