

Gear Motor 29 flat
1.61.065.4XX

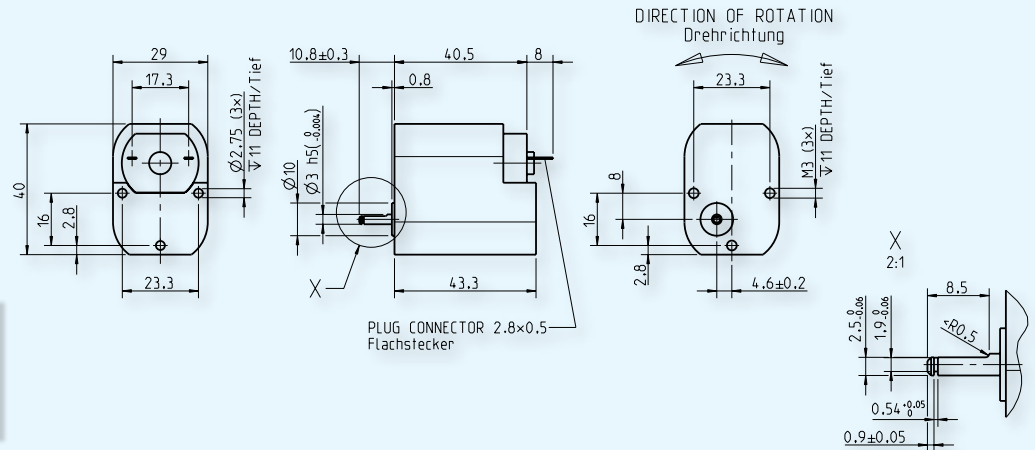

■ Type / Baureihe 1.61.065.XXX

XXX	Characteristics* / Nenndaten*					No load characteristics* / Leerlaufdaten*		Features* / Kenndaten*			
	Rated voltage Nennspannung	Rated current Nennstrom	Rated torque Nenn Drehmoment	Rated speed Nenn Drehzahl	Rotation Drehrichtung	No load speed Leerlauf Drehzahl	No load current Leerlaufstrom	max. Torque max. Drehmoment	Terminal resistance Anschlusswiderstand	Gear ratio Unter- setzungs- verhältnis	Stages Stufen
	U/V / V	I _N / A	T _N /M _N / Ncm	n _N / rpm/min ⁻¹		n ₀ / rpm/min ⁻¹	I ₀ / A	T _{max} /M _{max} / Ncm	R / Ohm	i	
403	6	0.330	4.5	136	cw	190	0.125	6.3	6.5	27.4	4
404	6	0.330	9.0	64	ccw	91	0.125	12.6	6.5	56.6	5
405	6	0.280	15	34	cw	44	0.125	21	6.5	117	6
406	6	0.240	20	18	ccw	22	0.125	28	6.5	242	7
407	6	0.165	20	9.5	cw	10.5	0.125	28	6.5	499	8
408	6	0.150	20	4.8	ccw	5.1	0.125	42	6.5	1032	9
423	12	0.170	4.5	136	cw	190	0.060	6.3	27	27.4	4
424	12	0.170	9.0	64	ccw	91	0.060	12.6	27	56.6	5
425	12	0.140	15	34	cw	44	0.060	21	27	117	6
426	12	0.115	20	18	ccw	22	0.060	28	27	242	7
427	12	0.080	20	9.5	cw	10.5	0.060	28	27	499	8
428	12	0.065	20	4.8	ccw	5.1	0.060	42	27	1032	9
443	18	0.115	4.5	136	cw	190	0.050	6.3	61	27.4	4
444	18	0.115	9.0	64	ccw	91	0.050	12.6	61	56.6	5
445	18	0.100	15	34	cw	44	0.050	21	61	117	6
446	18	0.080	20	18	ccw	22	0.050	28	61	242	7
447	18	0.065	20	9.5	cw	10.5	0.050	28	61	499	8
448	18	0.055	20	4.8	ccw	5.1	0.050	42	61	1032	9
463	24	0.090	4.5	147	cw	202	0.045	6.3	93	27.4	4
464	24	0.090	9.0	69	ccw	97	0.045	12.6	93	56.6	5
465	24	0.080	15	35	cw	47	0.045	21	93	117	6
466	24	0.065	20	19	ccw	23	0.045	28	93	242	7
467	24	0.042	20	10	cw	11	0.045	28	93	499	8
468	24	0.038	20	5.3	ccw	5.5	0.045	42	93	1032	9

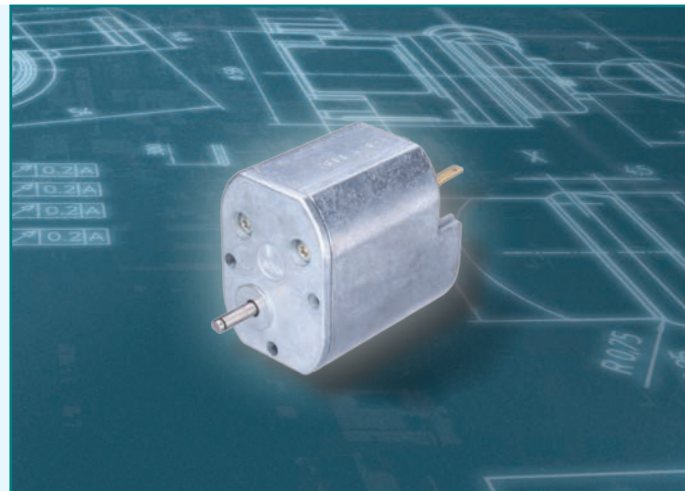

Design	
Gear housing	Zinc die-cast
Commutator	Copper / 3-segments
RFI protection	Suppression disk
Insulation class	Winding F, otherwise A
Protection class	IP20
Commutation	Carbon brushes
Armature	straight slot
Magnet system	Permanent magnets, 2-pole
Motor bearings	2 sintered bronze bearings
Motor housing	Steel, corrosion protected
Motor end shields	brush end plastic, drive end zinc die-cast
Spur gear	Metal and plastic gears
Life expectancy**	up to 1000 h
Weight	150 - 160 g
Axial play output shaft	0.05 - 0.6 mm

Aufbau	
Getriebegehäuse	Zinkdruckguss
Kollektor	Kupfer / 3-teilig
Grundentstörung	Entstörscheibe
Isolierstoffklasse	Wicklung F, ansonsten A
Schutzart	IP 20
Kommutierung	Kohlebürsten
Anker	gerade Nut
Magnetsystem	Permanentmagnete, 2-polig
Motorlager	2 ölgetränkte Sinterbronzelager
Motorgehäuse	Stahl, korrosionsgeschützt
Motorlagerschilde	kollektorseitig Kunststoff, abtriebsseitig Zinkdruckguss
Stirnradgetriebe	Zahnräder aus Metall und Kunststoff
Lebensdauer**	bis 1000 h
Gewicht	150 - 160 g
Axialspiel Abtriebswelle	0.05 - 0.6 mm

Operational conditions*	Einsatzbedingungen*			
Temperature range***	Temperaturbereich***	T	°C	-10 - +70
Axial force	Axialkraft	F _A	N	15
Radial force, 5 mm from mounting surface	Radialkraft, 5 mm ab Anschraubfläche	F _R	N	40

* at 25 °C

** depending on the operating conditions

*** extended temperature range on request

* bezogen auf 25 °C

** abhängig von den Einsatzbedingungen

*** erweiterter Temperaturbereich auf Anfrage